

## LED Driver with Average-Mode Constant Current Control



### General Description

The FP7175 is an average current mode control LED driver IC operating in a constant off-time mode. FP7175 does not produce a peak-to-average error, and therefore greatly improves accuracy, line and load regulation of the LED current without any need for loop compensation or high-side current sensing. The output LED current accuracy is  $\pm 2\%$ .

The FP7175 can be powered from an 8.0 - 100V supply. PWM & Linear dimming input is provided that accepts an external control TTL compatible signal. The output current can be programmed by an internal 250mV reference.

### Features

- Fast Average Current Control
- Internal 8 to 100V Linear Regulator
- Linear and PWM Dimming Capability
- Output Short Circuit Protection with Skip Mode
- Requires Few External Components for Operation

### Applications

- DC/DC or AC/DC LED Driver Applications
- LED Street Lighting
- Back Lighting of Flat Panel Displays
- General Purpose Constant Current Source
- Signage and Decorative LED Lighting
- Chargers

### Typical Application Circuit

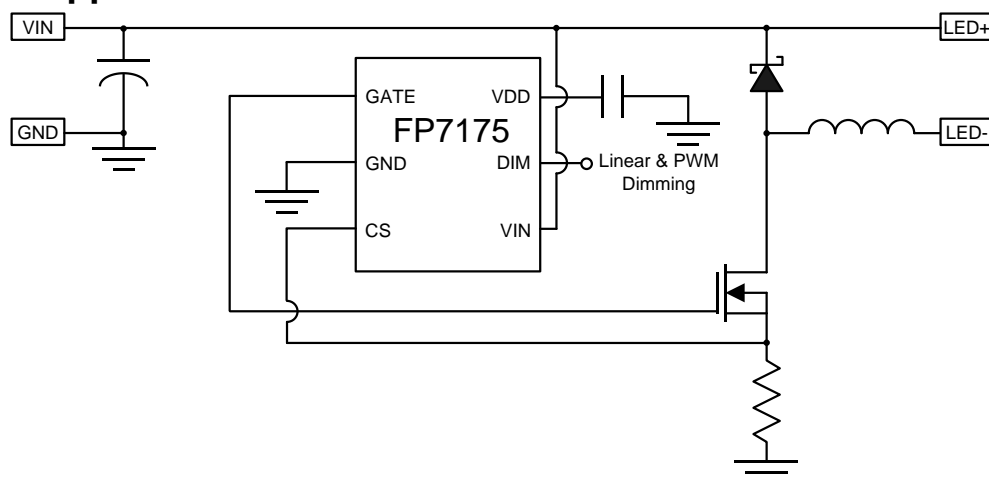

This datasheet contains new product information. Feeling Technology reserves the rights to modify the product specification without notice. No liability is assumed as a result of the use of this product. No rights under any patent accompany the sales of the product.

## Function Block Diagram

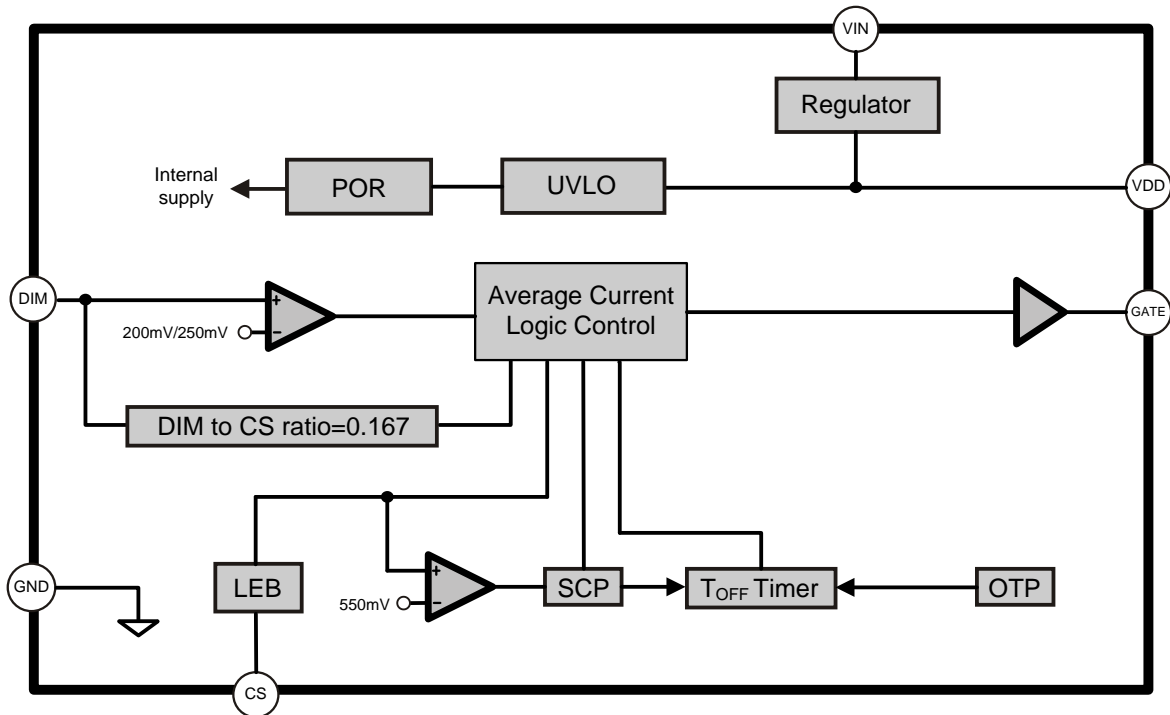

## Pin Descriptions

### SOT23-6L

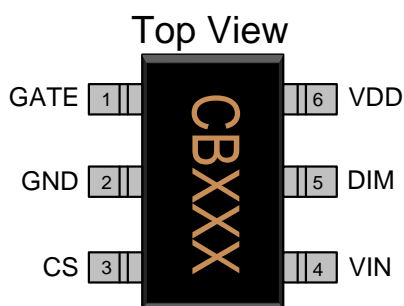

Name	No.	I / O	Description
GATE	1	O	This pin is the output GATE driver for an external N-channel power MOSFET.
GND	2	P	Ground return for all internal circuitry.
CS	3	I	This pin is the current sense pin used to sense the FET current by means of an external sense resistor.
VIN	4	P	This pin is the input of an 8 - 100V linear regulator.
DIM	5	I	This pin is the linear & PWM dimming input of the IC.
VDD	6	I	This is the power supply pin for all internal circuits.

## Marking Information

SOT23-6L

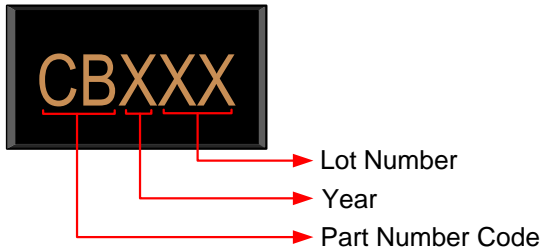

**Lot Number:** Wafer lot number's last two digits

For Example: XX486 → 86

**Year:** Production year's last digit

**Part Number Code:** Part number identification code for this product. It should be always "CB".

## Ordering Information

Part Number	Code	Operating Temperature	Package	MOQ	Description
FP7175LR-G1	CB	-25°C ~ +85°C	SOT23-6L	3000 EA	Tape & Reel

## Absolute Maximum Ratings

Parameter	Symbol	Conditions	Min.	Typ.	Max.	Unit
Power Supply Voltage	$V_{IN}$	$V_{IN}$ to GND			100	V
	$V_{DD}$	$V_{DD}$ to GND			8.5	V
CS, DIM, GATE			-0.3		$V_{DD}-0.3V$	V
Allowable Power Dissipation	$P_D$	SOT23-6L $T_A \leq +25^\circ C$			455	mW
Junction to Ambient Thermal Resistance	$\theta_{JA}$				220	$^\circ C / W$
Operating Temperature			-25		+85	$^\circ C$
Storage Temperature	$T_S$	SOT23-6L	-40		+150	$^\circ C$
SOT23-6L Lead Temperature		(soldering, 10 sec)			+260	$^\circ C$

## IR Re-flow Soldering Curve

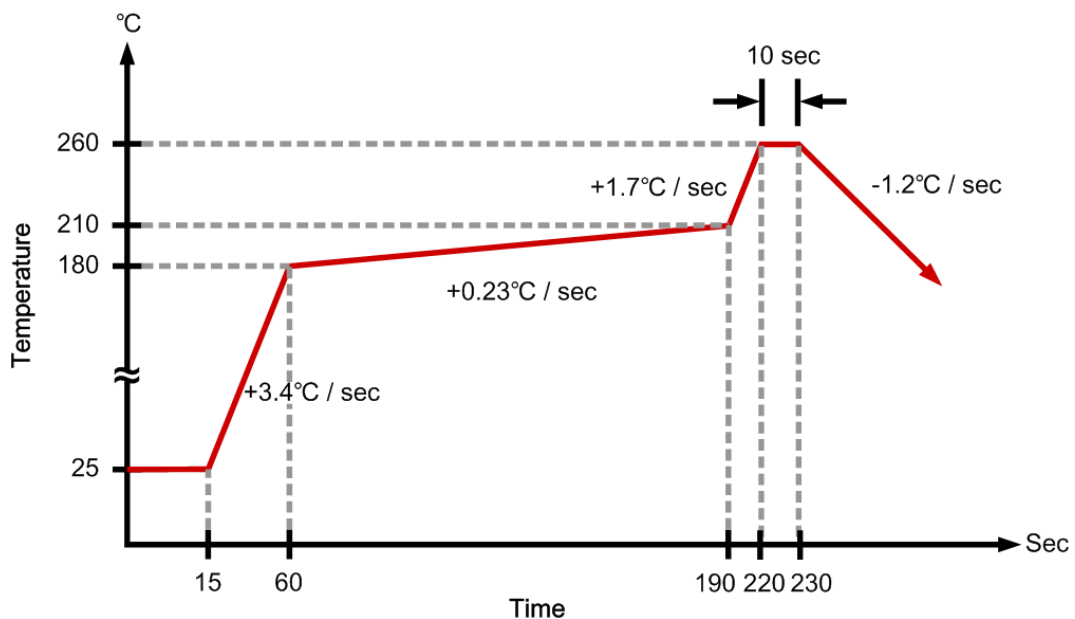

This datasheet contains new product information. Feeling Technology reserves the rights to modify the product specification without notice. No liability is assumed as a result of the use of this product. No rights under any patent accompany the sales of the product.

## Recommended Operating Conditions

Parameter	Symbol	Conditions	Min.	Typ.	Max.	Unit
Supply Voltage	$V_{IN}$		8		100	V
Operating Temperature			-25		85	°C

## DC Electrical Characteristics ( $V_{IN}=11V, T_A = 25^\circ C$ , unless otherwise noted)

Parameter	Symbol	Conditions	Min.	Typ.	Max.	Unit
<b>Internal Regulator</b>						
Internally regulated voltage	$V_{DD}$	$V_{IN} = 8V, I_{DD(ext)} = 0, 500pF$ at GATE; DIM = VDD	7.25	7.5	7.75	V
Line regulation of VDD	$\Delta V_{DD,line}$	$V_{IN} = 8 - 100V, I_{DD(ext)} = 0, 500pF$ at GATE; DIM = VDD	0	-	1.0	V
Load regulation of $V_{DD}$	$\Delta V_{DD,load}$	$I_{DD(ext)} = 0 - 0.6mA, 500pF$ at GATE; DIM = VDD	0		100	mV
$V_{DD}$ undervoltage lockout threshold	UVLO	$V_{DD}$ rising		6.5		V
$V_{DD}$ undervoltage lockout hysteresis	$\Delta UVLO$	$V_{DD}$ falling		500		mV
<b>PWM Dimming</b>						
Pin DIM input low voltage	$V_{EN(lo)}$	$V_{IN} = 8 - 100V$			0.1	V
Pin DIM input high voltage	$V_{EN(hi)}$	$V_{IN} = 8 - 100V$	1.6			V
<b>Average Current Sense Logic</b>						
Current sense reference voltage	$V_{CS}$		245	250	255	mV
DIM-to-CS voltage ratio	$A_{V(DIM)}$			0.167		
DIM-to-CS voltage offset	$A_{V(DIM)}$ (OFFSET)	Offset = $V_{CS} - A_{V(DIM)} \cdot V_{DIM}$ $V_{DIM}=1.2V$	0		10	mV
CS threshold temp regulation					5	mV
DIM input voltage, shutdown	$V_{DIM(OFF)}$			200		mV
DIM input voltage, enable	$\Delta V_{DIM(OFF)}$			250		mV
Current sense blanking interval	$T_{BLANK}$		150		320	ns
Minimum steady-state duty cycle	$T_{ON(min)}$	$CS=V_{CS} + 30mV$			1000	ns
<b>Short Circuit Protection</b>						
Hiccup threshold voltage	$V_{CS}$		495	550	605	mV
Current limit delay CS - GATE	$T_{DELAY}$	$CS=V_{CS} + 30mV$			150	ns
Short circuit hiccup time	$T_{HICCUP}$		450	550	650	us
Minimum on-time (short circuit)	$T_{ON(min)}$	$CS=V_{DD}$			600	ns
<b>GATE Driver</b>						
GATE sourcing current	$I_{SOURCE}$	$V_{GATE} = 0V, V_{DD} = 7.5V$	165			mA
GATE sinking current	$I_{SINK}$	$V_{GATE} = V_{DD}, V_{DD} = 7.5V$	165			mA
GATE output rise time	$t_{RISE}$	$C_{GATE} = 500pF, V_{DD} = 7.5V$		30	50	ns
GATE output fall time	$t_{FALL}$	$C_{GATE} = 500pF, V_{DD} = 7.5V$		30	50	ns

This datasheet contains new product information. Feeling Technology reserves the rights to modify the product specification without notice. No liability is assumed as a result of the use of this product. No rights under any patent accompany the sales of the product.

Parameter	Symbol	Conditions	Min.	Typ.	Max.	Unit
<b>OFF-Time</b>						
Minimum off time	T <sub>OFF(MIM)</sub>			0.6		us
Maximum off time	T <sub>OFF(MAX)</sub>			50		us
Maximum on time	T <sub>ON(MAX)</sub>			60		us

This datasheet contains new product information. Feeling Technology reserves the rights to modify the product specification without notice.  
No liability is assumed as a result of the use of this product. No rights under any patent accompany the sales of the product.

## Function Description

### Input Voltage Regulator

The FP7175 can be powered directly from its VIN pin and can work from 8.5 - 100VDC at its VIN pin. When a voltage is applied at the VIN pin, the FP7175 maintains a constant 7.5V at the VDD pin. This voltage is used to power the IC and any external resistor dividers needed to control the IC. The VDD pin must be bypassed by a low ESR capacitor to provide a low impedance path for the high frequency current of the output GATE driver.

The FP7175 can also be operated by supplying a voltage at the VDD pin greater than the internally regulated voltage. This will turn off the internal linear regulator of the IC and the FP7175 will operate directly off the voltage supplied at the VDD pin. Please note that this external voltage at the VDD pin should not exceed 8.5V.

In the above equation,  $f_s$  is the switching frequency and QG is the GATE charge of the external FET (which can be obtained from the datasheet of the FET).

### Average Current Control

The LED current is detected using a sense resistor at the CS pin. The feedback operates in a fast open-loop mode. No compensation is required. When the voltage at the DIM input  $V_{DIM} \geq 1.5V$ , output current is programmed simply as:

$$I_{LED}(A) = \frac{0.25V}{R_{CS}(\Omega)}$$

Otherwise:

$$I_{LED}(A) = \frac{V_{DIM}(V) \times 0.167}{R_{CS}(\Omega)}$$

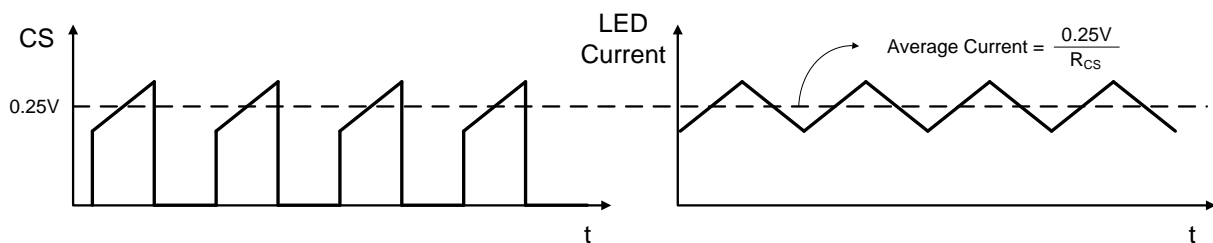

The above equations are only valid for continuous conduction of the output inductor. It is a good practice to design the inductor such that the switching ripple current in it is 25% of its average peak-to-peak, full load, DC current.

### GATE Output

The GATE output of the FP7175 is used to drive an external MOSFET. It is recommended that the gate charge QG of the external MOSFET be less than 25nC for switching frequencies  $\leq 100kHz$  and less than 15nC for switching frequencies  $> 100kHz$ .



### Output Short Circuit Protection

The short circuit protection comparator trips when the voltage at CS exceeds 0.55V. When this occurs, the GATE off-time  $T_{HICCUP} = 550\mu s$  is generated to prevent stair-casing of the inductor current and potentially its saturation due to insufficient output voltage.

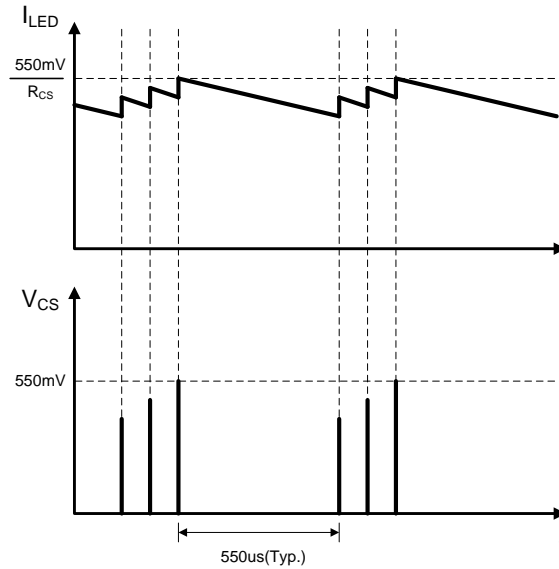

### Linear Dimming

When the voltage at DIM falls below 1.5V, the internal 250mV reference to the constant-current feedback becomes overridden by  $V_{DIM} \cdot 0.167$ . As long as the current in the inductor remains continuous, the LED current is given by the equation above. However, when  $V_{DIM}$  falls below 200mV, the GATE output becomes disabled. The GATE signal recovers, when  $V_{DIM}$  exceeds 250mV. This is required in some applications to be able to shut the LED lamp off with the same signal input that controls the brightness.

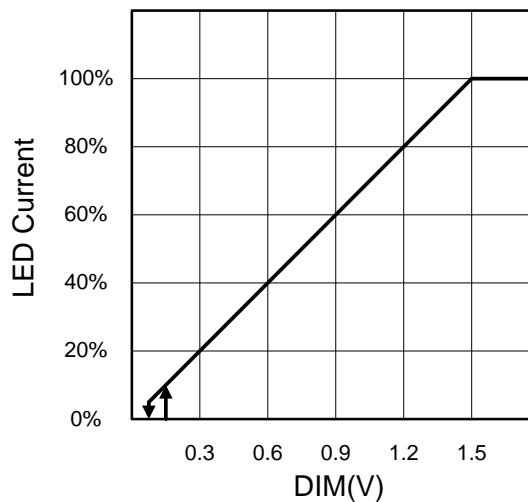

This datasheet contains new product information. Feeling Technology reserves the rights to modify the product specification without notice. No liability is assumed as a result of the use of this product. No rights under any patent accompany the sales of the product.

## PWM Dimming

Due to the fast open-loop response of the average-current control loop of the FP7175, its PWM dimming performance nearly matches that of the FP7171.

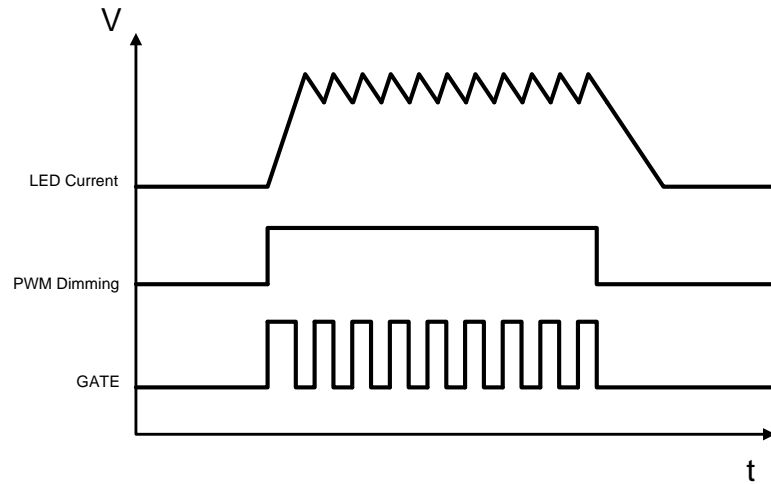

The rising and falling edges are limited by the current slew rate in the inductor. The first switching cycle is terminated upon reaching the 250mV ( $V_{DIM} \cdot 0.167$ ) level at CS. The circuit is further reaching its steady-state within 1 switching cycles regardless of the switching frequency.

※  $V_{IN}=12V$ ,  $LED=9.2V$ ,  $T_A = 25^{\circ}C$ , unless otherwise noted

Input Voltage VS LED Current

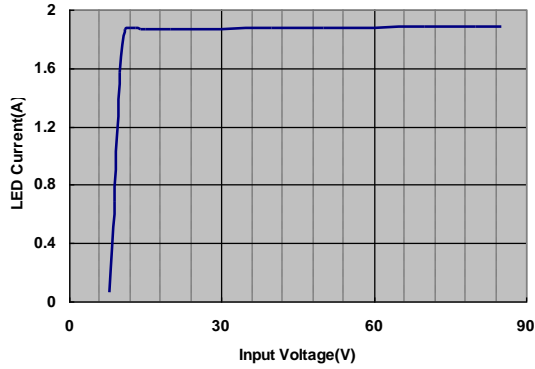

Input Voltage VS Frequency

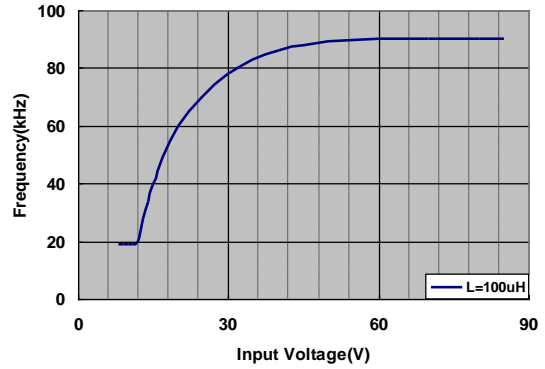

LED Voltage VS LED Current

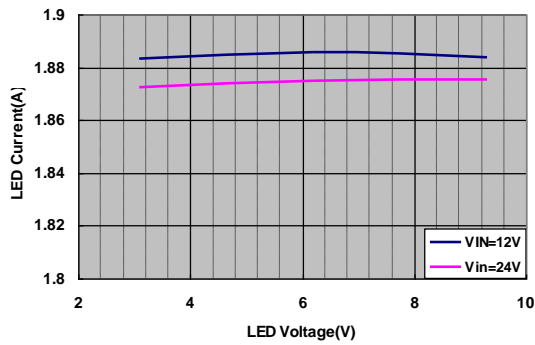

Inductor VS LED Current

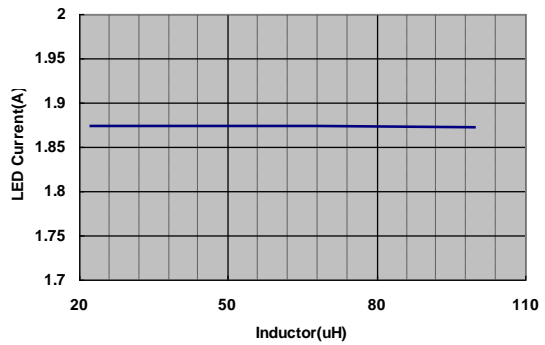

DIM Voltage VS LED Current

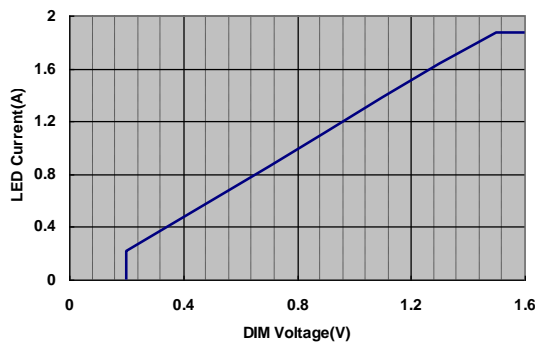

PWM Duty VS LED Current

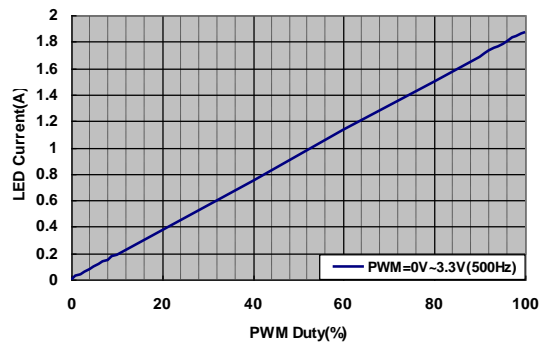

This datasheet contains new product information. Feeling Technology reserves the rights to modify the product specification without notice. No liability is assumed as a result of the use of this product. No rights under any patent accompany the sales of the product.

**Suggested Layout**

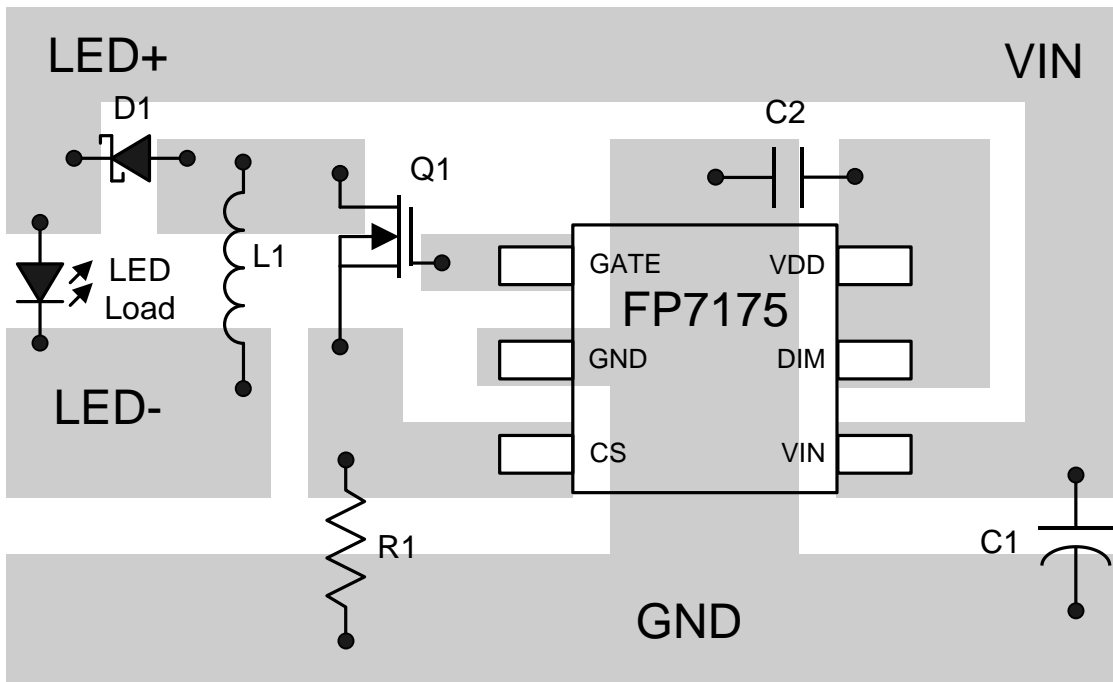

This datasheet contains new product information. Feeling Technology reserves the rights to modify the product specification without notice. No liability is assumed as a result of the use of this product. No rights under any patent accompany the sales of the product.

## Typical Application Circuit

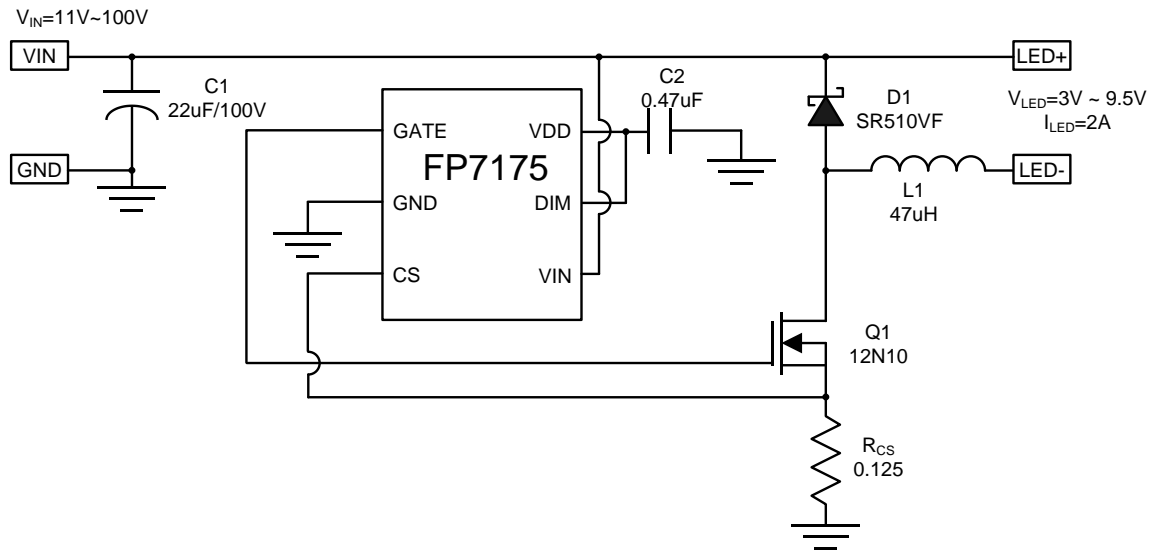

This datasheet contains new product information. Feeling Technology reserves the rights to modify the product specification without notice. No liability is assumed as a result of the use of this product. No rights under any patent accompany the sales of the product.

## Package Outline

SOT23-6L

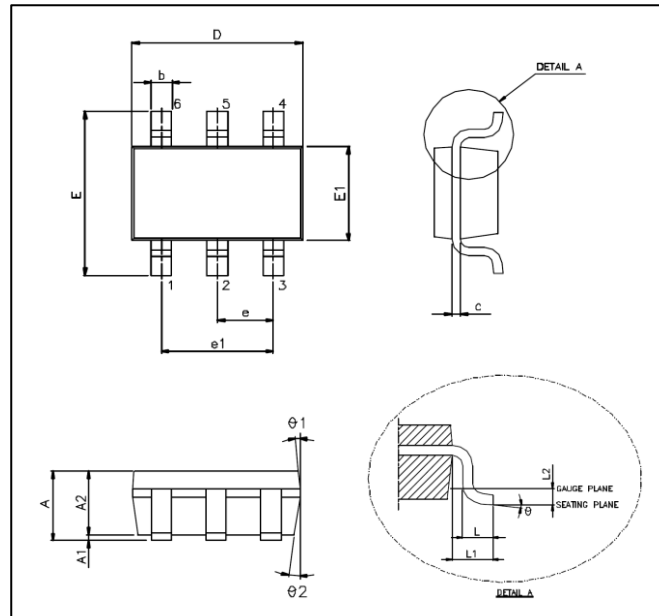

Unit: mm

Symbols	Min. (mm)	Max. (mm)
A	1.050	1.450
A1	0.050	0.150
A2	0.900	1.300
b	0.300	0.500
c	0.080	0.220
D	2.900 BSC	
E	2.800 BSC	
E1	1.600 BSC	
e	0.950 BSC	
e1	1.900 BSC	
L	0.300	0.600
L1	0.600 REF	
L2	0.250 BSC	
$\theta^\circ$	0°	8°
$\theta1^\circ$	3°	7°
$\theta2^\circ$	6°	15°

### Note:

1. Package dimensions are in compliance with JEDEC outline: MO-178 AB.
2. Dimension "D" does not include molding flash, protrusions or gate burrs.
3. Dimension "E1" does not include inter-lead flash or protrusions.

This datasheet contains new product information. Feeling Technology reserves the rights to modify the product specification without notice. No liability is assumed as a result of the use of this product. No rights under any patent accompany the sales of the product.