

bq500101 NexFET™功率级

1 特性

- 5A 电流时系统效率达 98%
- 最大额定持续电流 10A，峰值 15A
- 高频工作（高达 600kHz）
- 高密度小外形尺寸无引线 (SON) 3.5mm x 4.5mm 封装
- 超低电感封装
- 系统已优化的印刷电路板 (PCB) 封装
- 3.3V 和 5V 脉宽调制 (PWM) 信号兼容
- 输入电压高达 24V
- 集成型自举二极管
- 击穿保护
- 符合 RoHS 绿色环保标准-无铅引脚镀层
- 无卤素
- 包含高效栅极驱动器和场效应管 (FET) 的优化型功率级
- 针对 15W 无线电源发射器设计进行了优化

2 应用

- 用于 15W 或 5W 系统的无线电源发射器，符合 WPC (Qi) 1.2 规范
- 专用无线充电器和发射器
- 以无线方式供电的工业和医疗系统
- 更多相关信息，请访问 www.ti.com/wirelesspower

3 说明

bq500101 NexFET™功率级针对涵盖 WPC v1.2 中等功率规范的无线电源应用进行了优化。该器件既可用于固定频率发射器类型中的电源轨电压控制，也可用于固定频率和频率可变两种发射器类型中的线圈驱动器。这个组合在小型 3.5mm x 4.5mm 外形尺寸封装中实现具有高电流、高效率 and 高速开关功能的器件。此外，印刷电路板 (PCB) 封装已经过优化，可帮助减少设计时间并简化总体系统设计的完成。

器件信息(1)

订货编号	封装	封装尺寸 (标称值)
bq500101	DPC (9)	3.5mm x 4.5mm

(1) 要了解所有可用封装，请见数据表末尾的可订购产品附录。

应用图表

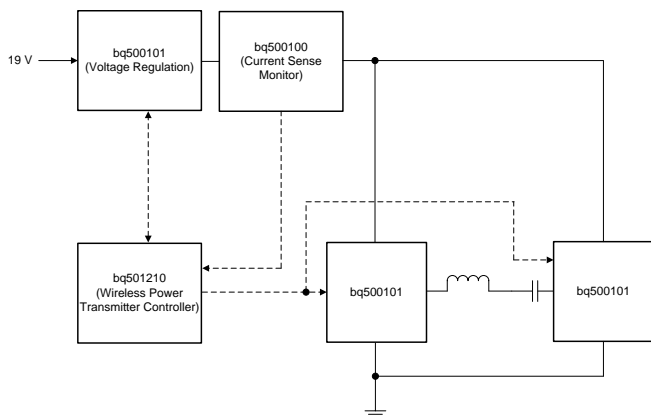

典型功率级效率与功率损耗

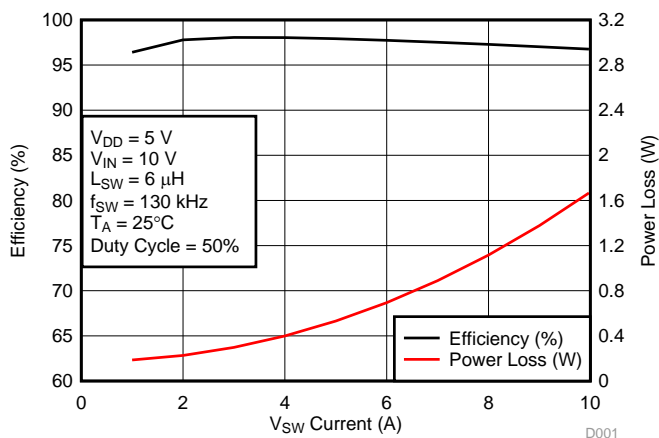

D001



目录

<ul style="list-style-type: none"> 1 特性 1 2 应用 1 3 说明 1 4 修订历史记录 2 5 Pin Configuration and Functions 3 6 Specifications 4 <ul style="list-style-type: none"> 6.1 Absolute Maximum Ratings 4 6.2 ESD Ratings 4 6.3 Recommended Operating Conditions 4 6.4 Thermal Information 4 6.5 Electrical Characteristics 5 7 Detailed Description 6 <ul style="list-style-type: none"> 7.1 Overview 6 7.2 Functional Block Diagram 6 7.3 Feature Description 7 	<ul style="list-style-type: none"> 8 Application and Implementation 8 <ul style="list-style-type: none"> 8.1 Application Information 8 8.2 Typical Application 8 8.3 System Example 11 9 Layout 13 <ul style="list-style-type: none"> 9.1 Layout Guidelines 13 9.2 Layout Example 13 9.3 Thermal Considerations 14 10 器件和文档支持 15 <ul style="list-style-type: none"> 10.1 商标 15 10.2 静电放电警告 15 10.3 Glossary 15 11 机械、封装和可订购信息 16 <ul style="list-style-type: none"> 11.1 机械制图 16 11.2 建议印刷电路板 (PCB) 焊盘图案 17 11.3 建议模板开口 17
---	--

4 修订历史记录

日期	修订版本	注释
2016 年 3 月	*	首次发布。

5 Pin Configuration and Functions

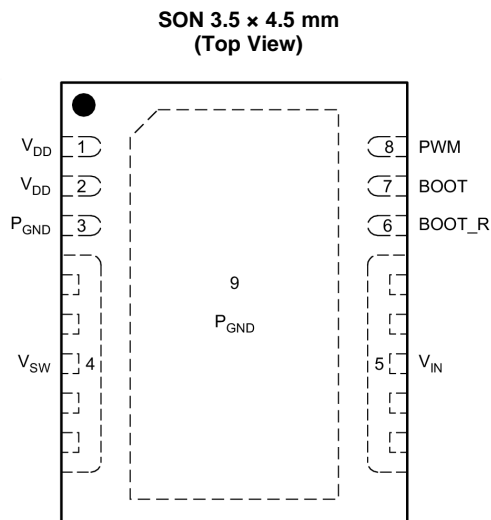

Pin Functions

PIN		DESCRIPTION
NO.	NAME	
1	V _{DD}	Supply voltage to gate drivers and internal circuitry.
2	V _{DD}	Supply voltage to gate drivers and internal circuitry.
3	P _{GND}	Power ground, needs to be connected to Pin 9 and PCB
4	V _{SW}	Voltage switching node – pin connection to the inductor.
5	V _{IN}	Input voltage pin. Connect input capacitors close to this pin.
6	BOOT_R	Bootstrap capacitor C _{BOOT} connections. Connect a minimum 0.1 μF 16 V X5R, ceramic cap C _{BOOT} from BOOT to BOOT_R pins. The bootstrap capacitor provides the charge to turn on the Control FET. The bootstrap diode is integrated. Boot_R is internally connected to V _{SW} .
7	BOOT	
8	PWM	Pulse Width modulated tri-state input from external controller. Logic Low sets Control FET gate low and Sync FET gate high. Logic High sets Control FET gate high and Sync FET gate Low. Open or High Z sets both MOSFET gates low if greater than the tri-state shutdown hold-off time (t _{3HT})
9	P _{GND}	Power ground

6 Specifications

6.1 Absolute Maximum Ratings⁽¹⁾

 $T_A = 25^\circ\text{C}$ (unless otherwise noted)

		MIN	MAX	UNIT
V_{IN} to P_{GND}		-0.3	30	V
V_{SW} to P_{GND} , V_{IN} to V_{SW}		-0.3	30	V
V_{SW} to P_{GND} , V_{IN} to V_{SW} (<10 ns)		-7	33	V
V_{DD} to P_{GND}		-0.3	6	V
PWM		-0.3	6	V
BOOT to P_{GND}		-0.3	35	V
BOOT to P_{GND} (<10 ns)		-2	38	V
BOOT to BOOT_R		-0.3	6	V
BOOT to BOOT_R (duty cycle <0.2%)			8	V
P_D	Power dissipation		8	W
T_J	Operating temperature	-40	150	$^\circ\text{C}$
T_{stg}	Storage temperature	-55	150	$^\circ\text{C}$

(1) Stresses above those listed in *Absolute Maximum Ratings* may cause permanent damage to the device. These are stress ratings only and functional operation of the device at these or any other conditions beyond those indicated under *Recommended Operating Conditions* is not implied. Exposure to Absolute Maximum rated conditions for extended periods may affect device reliability.

6.2 ESD Ratings

			VALUE	UNIT
$V_{(ESD)}$	Electrostatic discharge	Human body model (HBM) ⁽¹⁾	± 2000	V
		Charged device model (CDM) ⁽²⁾	± 500	

(1) JEDEC document JEP155 states that 500 V HBM allows safe manufacturing with a standard ESD control process.

(2) JEDEC document JEP157 states that 250 V CDM allows safe manufacturing with a standard ESD control process.

6.3 Recommended Operating Conditions

 $T_A = 25^\circ$ (unless otherwise noted)

			MIN	MAX	UNIT
V_{DD}	Gate drive voltage		4.5	5.5	V
V_{IN}	Input supply voltage ⁽¹⁾			24	V
I_{SW}	Continuous V_{SW} current	$V_{IN} = 10\text{ V}$, $V_{DD} = 5\text{ V}$, Duty cycle = 50%, $f_{SW} = 130\text{ kHz}$, $L_{SW} = 6\ \mu\text{H}$ ⁽²⁾		10	A
I_{SW-PK}	Peak V_{SW} current ⁽³⁾			15	A
f_{SW}	Switching frequency	$C_{BOOT} = 0.1\ \mu\text{F}$ (min)		600	kHz
	On time duty cycle			85%	
	Minimum PWM on time		40		ns
	Operating temperature		-40	125	$^\circ\text{C}$

(1) Operating at high V_{IN} can create excessive AC voltage overshoots on the switch node (V_{SW}) during MOSFET switching transients. For reliable operation, the switch node (V_{SW}) to ground voltage must remain at or below the *Absolute Maximum Ratings*.

(2) Measurement made with six 10 μF (TDK C3216X5R1C106KT or equivalent) ceramic capacitors placed across V_{IN} to P_{GND} pins.

(3) System conditions as defined in Note 2. Peak V_{SW} Current is applied for $t_p = 10\text{ ms}$, duty cycle $\leq 1\%$

6.4 Thermal Information

 $T_A = 25^\circ\text{C}$ (unless otherwise noted)

THERMAL METRIC		MIN	TYP	MAX	UNIT
$R_{\theta JC}$	Junction-to-case (top of package) thermal resistance ⁽¹⁾			22.8	$^\circ\text{C/W}$
$R_{\theta JB}$	Junction-to-board thermal resistance ⁽²⁾			2.5	

(1) $R_{\theta JC}$ is determined with the device mounted on a 1 inch² (6.45 cm²), 2 oz (0.071 mm thick) Cu pad on a 1.5 inch x 1.5 inch, 0.06 inch (1.52 mm) thick FR4 board.

(2) $R_{\theta JB}$ value based on hottest board temperature within 1mm of the package.

6.5 Electrical Characteristics

 $T_A = 25^\circ\text{C}$, $V_{DD} = \text{POR to } 5.5 \text{ V}$ (unless otherwise noted)

PARAMETER		TEST CONDITIONS	MIN	TYP	MAX	UNIT
P_{Loss}						
Power loss ⁽¹⁾		$V_{IN} = 10 \text{ V}$, $V_{DD} = 5 \text{ V}$, $I_{SW} = 5 \text{ A}$, $f_{SW} = 130 \text{ kHz}$, $L_{SW} = 6 \mu\text{H}$, $T_J = 25^\circ\text{C}$, Duty Cycle = 50%		0.53		W
Power loss ⁽¹⁾		$V_{IN} = 10 \text{ V}$, $V_{DD} = 5 \text{ V}$, $I_{SW} = 5 \text{ A}$, $f_{SW} = 130 \text{ kHz}$, $L_{SW} = 6 \mu\text{H}$, $T_J = 125^\circ\text{C}$, Duty Cycle = 50%		0.68		W
V_{IN}						
I_Q	V_{IN} quiescent current	PWM = Floating, $V_{DD} = 5 \text{ V}$, $V_{IN} = 24 \text{ V}$			1	μA
V_{DD}						
I_{DD}	Standby supply current	PWM = Float		130		μA
I_{DD}	Operating supply current	PWM = 50% Duty cycle, $f_{SW} = 130 \text{ kHz}$		2		mA
POWER-ON RESET AND UNDERVOLTAGE LOCKOUT						
V_{DD} Rising	Power-on reset				4.15	V
V_{DD} Falling	UVLO		3.7			V
	Hysteresis			0.2		V
PWM I/O SPECIFICATIONS						
R_I	Input impedance	Pull up to V_{DD}		1700		k Ω
		Pull down (to GND)		800		
V_{IH}	Logic level high		2.65			V
V_{IL}	Logic level low			0.6		
V_{IH}	Hysteresis			0.2		
V_{TS}	Tri-state voltage		1.3		2	
$t_{THOLD(off1)}$	Tri-state activation time (falling) PWM			60		ns
$t_{THOLD(off2)}$	Tri-state activation time (rising) PWM			60		
$t_{3RD(PWM)}$	Tri-state exit time PWM ⁽¹⁾				100	ns
BOOTSTRAP SWITCH						
V_{FBST}	Forward voltage	$I_F = 10 \text{ mA}$		120	240	mV
I_{RLEAK}	Reverse leakage ⁽¹⁾	$V_{BOOT} - V_{DD} = 25 \text{ V}$			2	μA

(1) Specified by design

7 Detailed Description

7.1 Overview

The bq500101 NexFET™ Power Stage is a highly optimized design for use in wireless power transmitter designs. The bq500101 can also be used for synchronous buck applications.

7.2 Functional Block Diagram

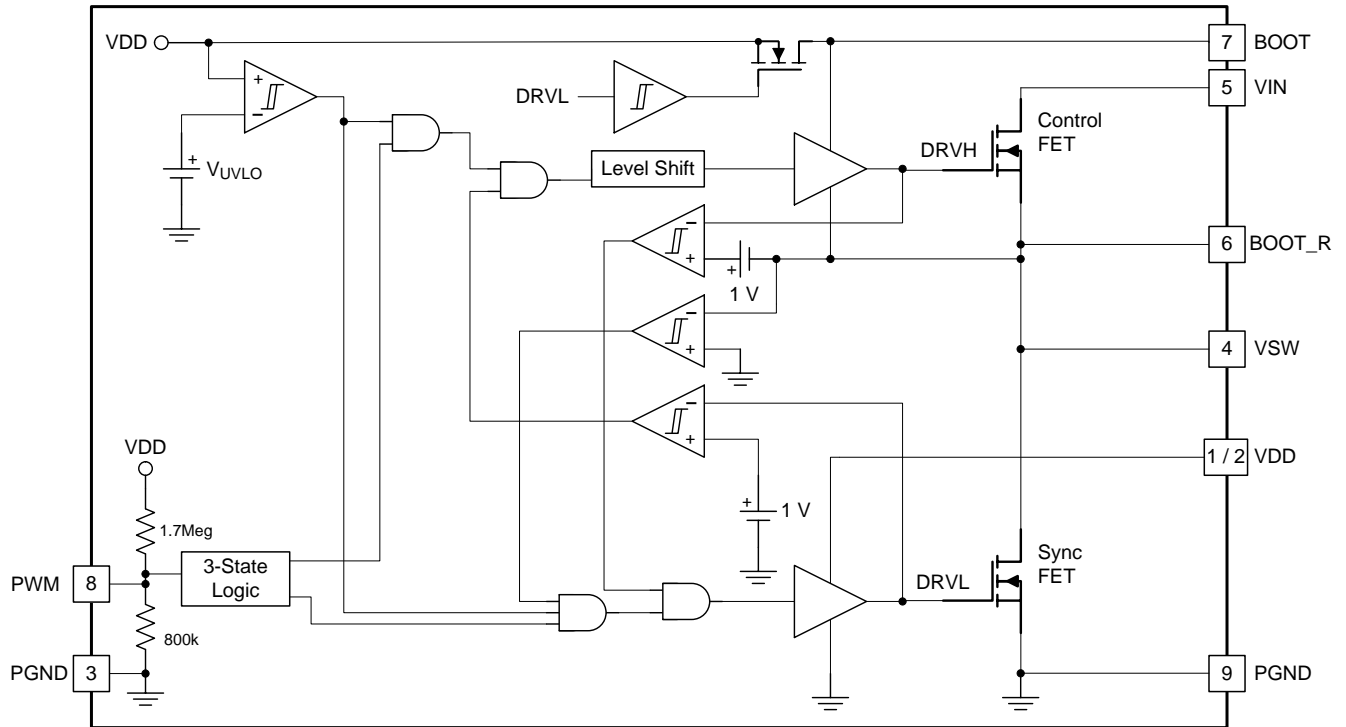

7.3 Feature Description

7.3.1 Powering bq500101 And Gate Drivers

An external V_{DD} voltage is required to supply the integrated gate driver device and provide the necessary gate drive power for the MOSFETS. A 1- μ F 10-V X5R or higher ceramic capacitor is recommended to bypass V_{DD} pin to P_{GND} . A bootstrap circuit to provide gate drive power for the Control FET is also included. The bootstrap supply to drive the Control FET is generated by connecting a 100-nF 16-V X5R ceramic capacitor C_{BOOT} between BOOT and BOOT_R pins. An optional R_{BOOT} resistor in series with C_{BOOT} can be used to slow down the turn on speed of the Control FET and reduce voltage spikes on the V_{SW} node. A typical 1 Ω to 4.7 Ω value is a compromise between switching loss and V_{SW} spike amplitude.

7.3.2 Undervoltage Lockout Protection (UVLO)

The undervoltage lockout (UVLO) comparator evaluates the V_{DD} voltage level. As V_{VDD} rises, both the Control FET and Sync FET gates hold actively low at all times until V_{VDD} reaches the higher UVLO threshold (V_{UVLO_H}). Then the driver becomes operational and responds to PWM command. If V_{DD} falls below the lower UVLO threshold ($V_{UVLO_L} = V_{UVLO_H} - \text{Hysteresis}$), the device disables the driver and drives the outputs of the Control FET and Sync FET gates actively low. [Figure 1](#) shows this function.

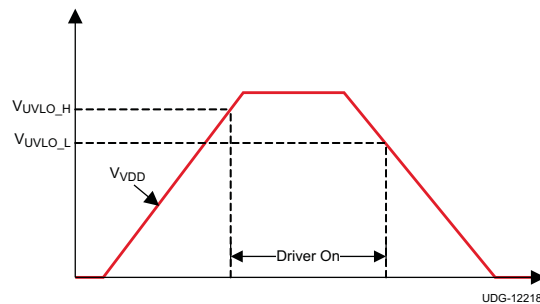

Figure 1. UVLO Operation

7.3.3 Integrated Boost-Switch

To maintain a $BOOT-V_{SW}$ voltage close to V_{DD} (to get lower conduction losses on the high-side FET), the conventional diode between the V_{DD} pin and the BOOT pin is replaced by a FET which is gated by the DRVL signal.

8 Application and Implementation

NOTE

Information in the following applications sections is not part of the TI component specification, and TI does not warrant its accuracy or completeness. TI's customers are responsible for determining suitability of components for their purposes. Customers should validate and test their design implementation to confirm system functionality.

8.1 Application Information

The Power Stage bq500101 is a highly optimized design for wireless power transmitter applications using NexFET devices with a 5-V gate drive. The Control FET and Sync FET silicon are parametrically tuned to yield the lowest power loss and highest system efficiency. As a result, a rating method is used that is tailored towards a more systems centric environment. The high-performance gate driver device integrated in the package helps minimize the parasitics and results in extremely fast switching of the power MOSFETs. System level performance curves such as Power Loss, Safe Operating Area and normalized graphs allow engineers to predict the product performance in the actual application.

8.2 Typical Application

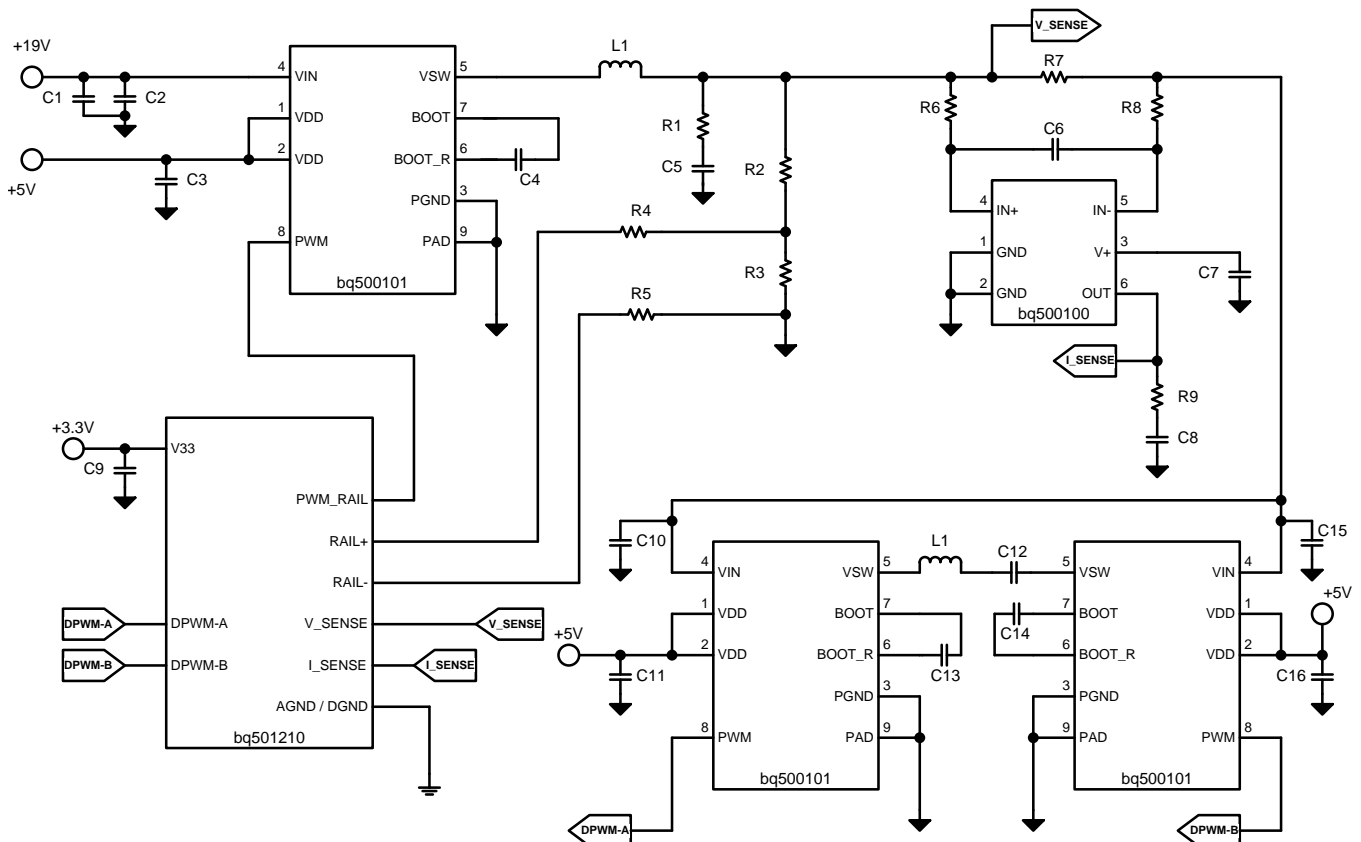

Figure 2. Application Schematic

Typical Application (continued)

8.2.1 Application Curves

T_J = 125°C, unless stated otherwise

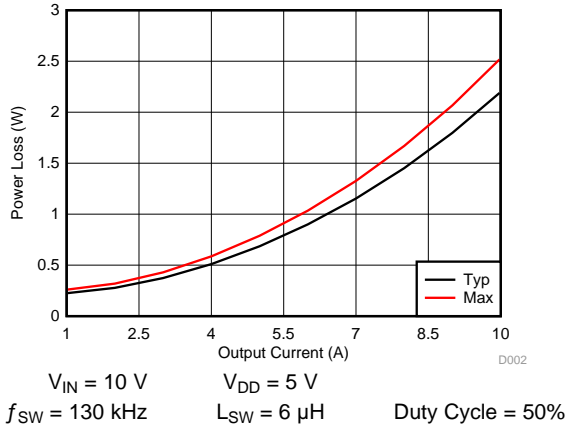

Figure 3. Power Loss vs Output Current

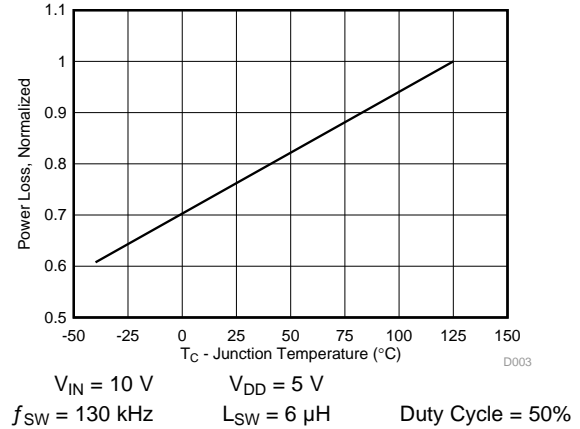

Figure 4. Power Loss vs Temperature

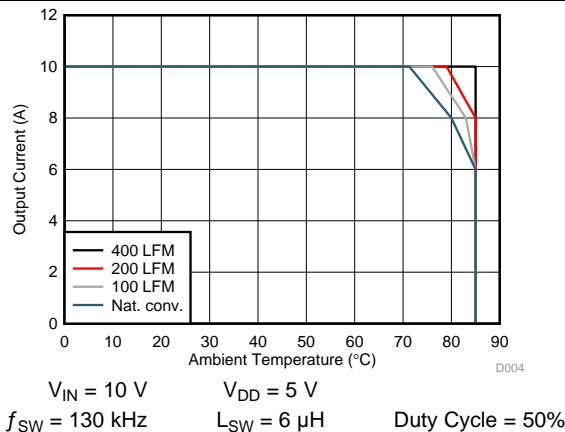

Figure 5. Safe Operating Area – PCB Horizontal Mount (1)

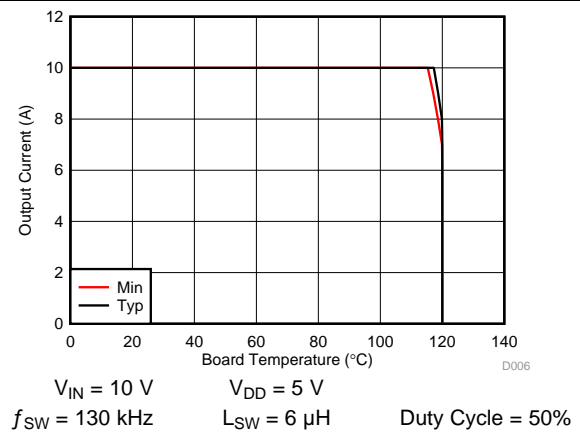

Figure 6. Typical Safe Operating Area

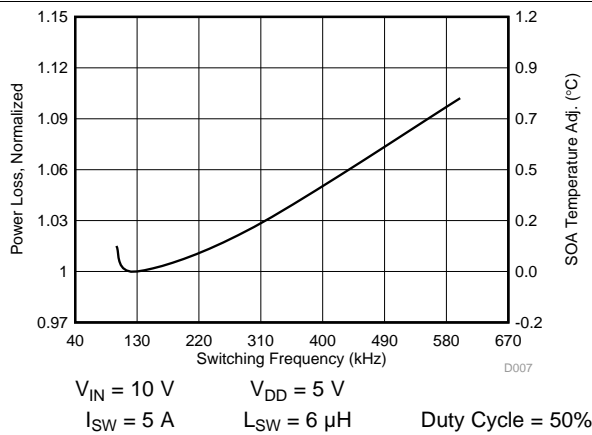

Figure 7. Normalized Power Loss vs Frequency

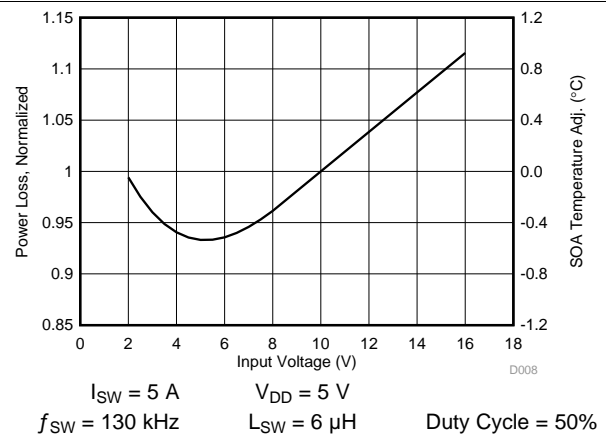
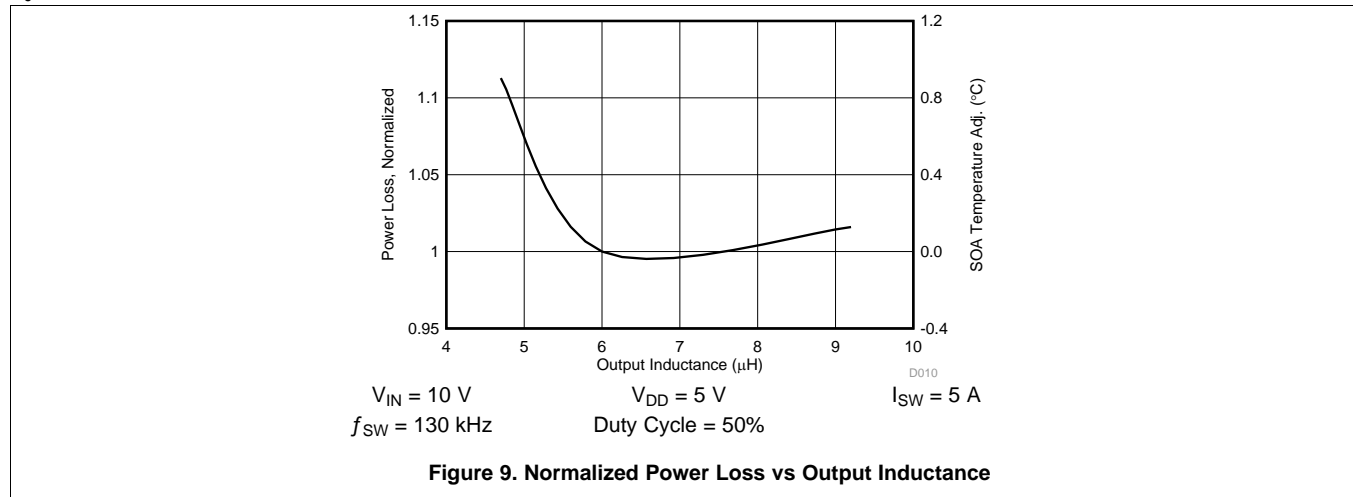

Figure 8. Normalized Power Loss vs Input Voltage

(1) LFM: Linear Feet per Minute (Air Flow Velocity)

Typical Application (continued)
 $T_J = 125^\circ\text{C}$, unless stated otherwise

1. The Typical bq500101 System Characteristic curves are based on measurements made on a PCB design with dimensions of 4.0 inches (W) × 3.5 inches (L) × 0.062 inch (T) and 6 copper layers of 1-oz. copper thickness. See the [System Example](#) section for detailed explanation.

$T_J = 125^\circ\text{C}$, unless stated otherwise

8.3 System Example

8.3.1 Power Loss Curves

MOSFET centric parameters such as ON-resistance and gate charges are primarily needed by engineers to estimate the loss generated by the devices. In an effort to simplify the design process for engineers, Texas Instruments has provided measured power loss performance curves. Figure 3 plots the power loss of the bq500101 as a function of load current. This curve is measured by configuring and running the bq500101 as the circuit shown in Figure 10. The measured power loss is the bq500101 device power loss which consists of both input conversion loss and gate drive loss. Equation 1 is used to generate the power loss curve.

$$\text{Power Loss} = (V_{IN} \times I_{IN}) + (V_{DD} \times I_{DD}) - (V_{SW_AVG} \times I_{OUT}) \quad (1)$$

The power loss curve in Figure 3 is measured at the maximum recommended junction temperature of $T_J = 125^\circ\text{C}$ under isothermal test conditions.

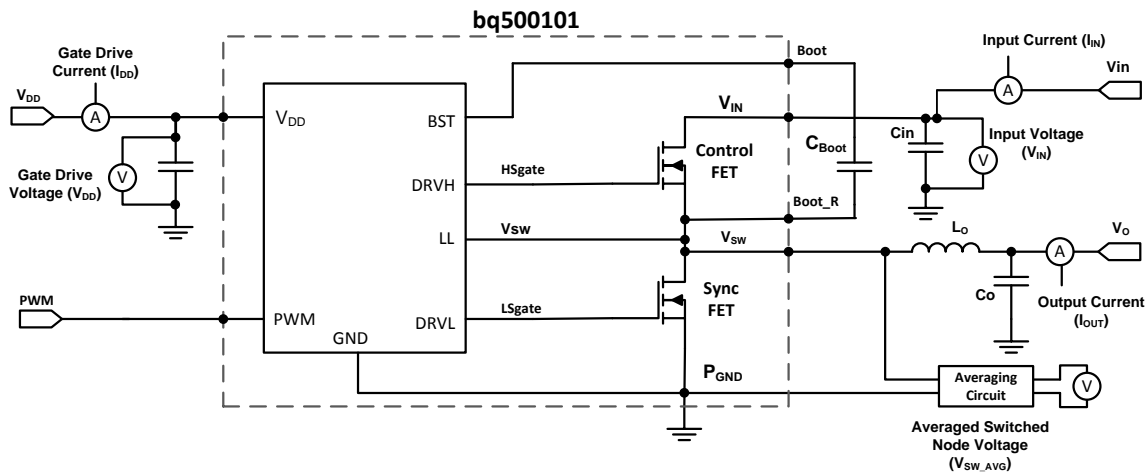

Figure 10. Power Loss Test Circuit

8.3.2 Safe Operating Area (SOA) Curves

The SOA curves in the bq500101 datasheet give engineers guidance on the temperature boundaries within an operating system by incorporating the thermal resistance and system power loss. Figure 5 and Figure 6 outline the temperature and airflow conditions required for a given load current. The area under the curve dictates the safe operating area. All the curves are based on measurements made on a PCB design with dimensions of 4.0" (W) x 3.5" (L) x 0.062" (T) and 6 copper layers of 1-oz. copper thickness.

8.3.3 Normalized Curves

The normalized curves in the bq500101 data sheet give engineers guidance on the Power Loss and SOA adjustments based on their application specific needs. These curves show how the power loss and SOA boundaries will adjust for a given set of systems conditions. The primary Y-axis is the normalized change in power loss and the secondary Y-axis is the change in system temperature required in order to comply with the SOA curve. The change in power loss is a multiplier for the Power Loss curve and the change in temperature is subtracted from the SOA curve.

System Example (continued)

8.3.3.1 Calculating Power Loss and SOA

The user can estimate product loss and SOA boundaries by arithmetic means (see the Design Example below). Though the Power Loss and SOA curves in this datasheet are taken for a specific set of test conditions, the following procedure will outline the steps engineers should take to predict product performance for any set of system conditions.

8.3.3.1.1 Design Example

Operating Conditions: Output Current (I_{SW}) = 9 A, Input Voltage (V_{IN}) = 8 V, Switching Frequency (f_{SW}) = 300 kHz, Output Inductor (L_{SW}) = 5 μ H, Duty Cycle = 50%.

8.3.3.1.2 Calculating Power Loss

- Typical Power Loss at 9 A = 1.78 W (Figure 3)
- Normalized Power Loss for switching frequency \approx 1.03 (Figure 7)
- Normalized Power Loss for input voltage \approx 0.96 (Figure 8)
- Normalized Power Loss for output inductor \approx 1.075 (Figure 9)
- **Final calculated Power Loss = 1.78 W \times 1.03 \times 0.96 \times 1.075 \approx 1.89 W**

8.3.3.1.3 Calculating SOA Adjustments

- SOA adjustment for switching frequency \approx 0.20°C (Figure 7)
- SOA adjustment for input voltage \approx -0.30°C (Figure 8)
- SOA adjustment for output inductor \approx 0.60°C (Figure 9)
- **Final calculated SOA adjustment = 0.2 + (-0.3) + 0.6 \approx 0.5°C**

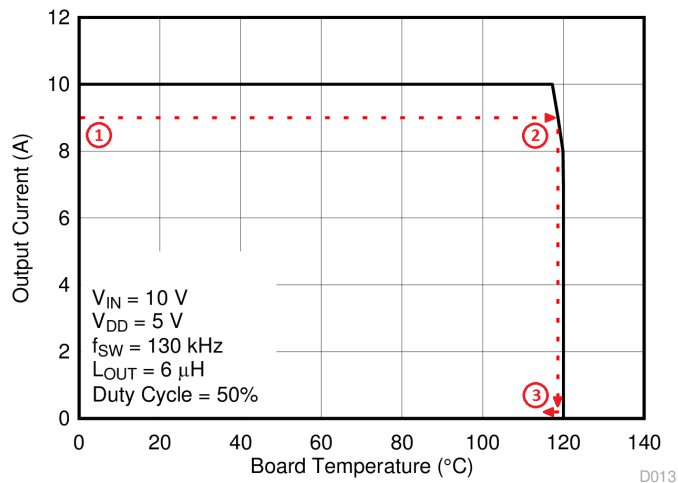

Figure 11. Power Stage bq500101 SOA, $T_A = 25^\circ\text{C}$

In the design example above, the estimated power loss of the bq500101 would increase to 1.89 W. In addition, the maximum allowable board and/or ambient temperature would have to decrease by 0.5°C. Figure 11 graphically shows how the SOA curve would be adjusted accordingly.

1. Start by drawing a horizontal line from the application current to the SOA curve.
2. Draw a vertical line from the SOA curve intercept down to the board/ambient temperature.
3. Adjust the SOA board/ambient temperature by subtracting the temperature adjustment value.

In the design example, the SOA temperature adjustment yields a reduction in allowable board/ambient temperature of 0.5°C. In the event the adjustment value is a negative number, subtracting the negative number would yield an increase in allowable board/ambient temperature.

9 Layout

9.1 Layout Guidelines

9.1.1 Recommended PCB Design Overview

There are two key system-level parameters that can be addressed with a proper PCB design: electrical and thermal performance. Properly optimizing the PCB layout will yield maximum performance in both areas. Below is a brief description on how to address each parameter.

9.1.2 Electrical Performance

The bq500101 has the ability to switch at voltage rates greater than 10 kV/ μ s. Special care must be then taken with the PCB layout design and placement of the input capacitors, inductor and switch capacitors (SW capacitors).

- The placement of the input capacitors relative to V_{IN} and P_{GND} pins of bq500101 device should have the highest priority during the component placement routine. It is critical to minimize these node lengths. As such, the ceramic input capacitor C1 needs to be placed as close as possible to the V_{IN} and P_{GND} pins (see Figure 12). Notice if there are input capacitors on both sides of the board, an appropriate amount of V_{IN} and GND vias need to be added to interconnect both layers..
- The bootstrap cap C_{BOOT} 0.1- μ F 0603 16-V ceramic capacitor C4 in Figure 12 should be closely connected between BOOT and BOOT_R pins.
- The switching node of the inductor should be placed relatively close to the Power Stage bq500101 V_{SW} pins. Minimizing the V_{SW} node length between these two components will reduce the PCB conduction losses and actually reduce the switching noise level. ⁽¹⁾

9.2 Layout Example

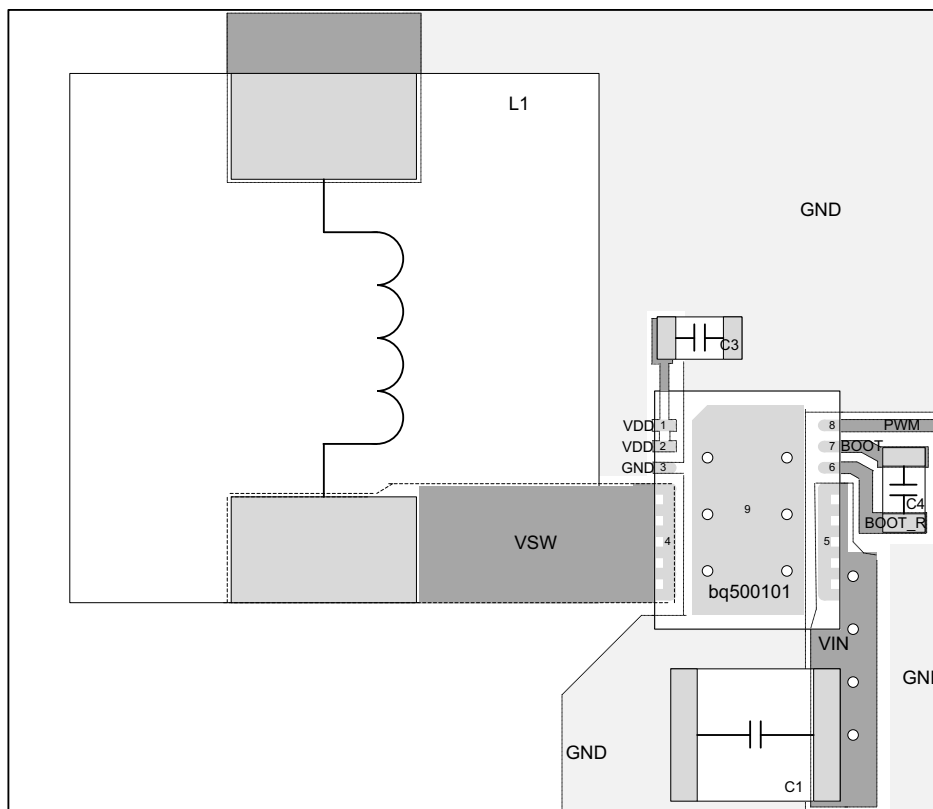

Figure 12. Recommended PCB Layout (Top Down View)

(1) Keong W. Kam, David Pommerenke, "EMI Analysis Methods for Synchronous Buck Converter EMI Root Cause Analysis", University of Missouri – Rolla

9.3 Thermal Considerations

The bq500101 has the ability to use the GND planes as the primary thermal path. As such, the use of thermal vias is an effective way to pull away heat from the device and into the system board. Concerns of solder voids and manufacturability problems can be addressed by the use of three basic tactics to minimize the amount of solder attach that will wick down the via barrel:

- Intentionally space out the vias from each other to avoid a cluster of holes in a given area.
- Use the smallest drill size allowed in your design. The example in [Figure 12](#) uses vias with a 10 mil drill hole and a 16 mil capture pad.
- Tent the opposite side of the via with solder-mask.

In the end, the number and drill size of the thermal vias should align with the end user's PCB design rules and manufacturing capabilities.

10 器件和文档支持

10.1 商标

NexFET is a trademark of Texas Instruments.
All other trademarks are the property of their respective owners.

10.2 静电放电警告



这些装置包含有限的内置 ESD 保护。存储或装卸时，应将导线一起截短或将装置放置于导电泡棉中，以防止 MOS 门极遭受静电损伤。

10.3 Glossary

[SLYZ022](#) — *TI Glossary*.

This glossary lists and explains terms, acronyms, and definitions.

11 机械、封装和可订购信息

以下页中包括机械、封装和可订购信息。这些信息是针对指定器件可提供的最新数据。这些数据会在无通知且不对本文档进行修订的情况下发生改变。要获得这份数据表的浏览器版本，请查阅左侧的导航栏。

11.1 机械制图

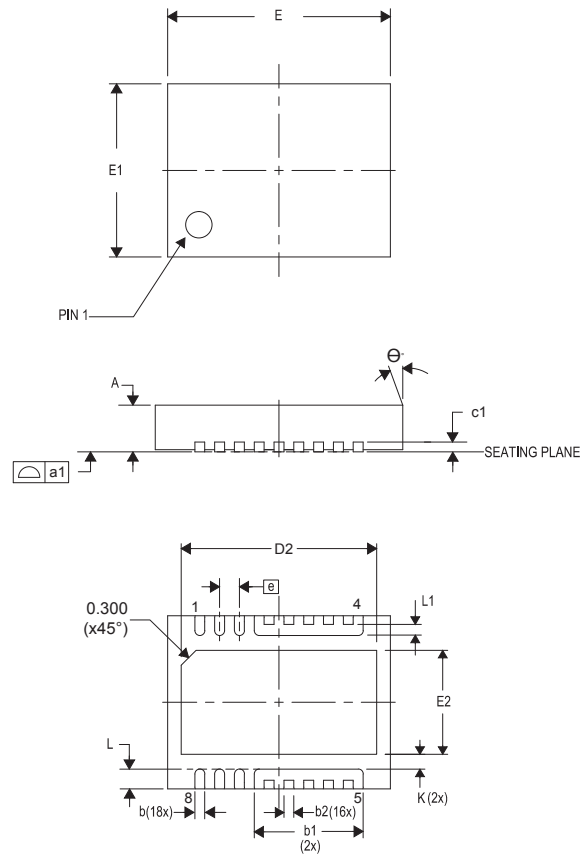

DIM	毫米			英寸		
	最小值	标称值	最大值	最小值	标称值	最大值
A	0.800	0.900	1.000	0.031	0.035	0.039
a1	0.000	0.000	0.080	0.000	0.000	0.003
b	0.150	0.200	0.250	0.006	0.008	0.010
b1	2.000	2.200	2.400	0.079	0.087	0.095
b2	0.150	0.200	0.250	0.006	0.008	0.010
c1	0.150	0.200	0.250	0.006	0.008	0.010
D2	3.850	3.950	4.050	0.152	0.156	0.160
E	4.400	4.500	4.600	0.173	0.177	0.181
E1	3.400	3.500	3.600	0.134	0.138	0.142
E2	2.000	2.100	2.200	0.079	0.083	0.087
e	0.400 典型值			0.016 典型值		
K	0.300 典型值			0.012 典型值		
L	0.300	0.400	0.500	0.012	0.016	0.020
L1	0.180	0.230	0.280	0.007	0.009	0.011
θ	0.00	—	—	0.00	—	—

11.2 建议印刷电路板 (PCB) 焊盘图案

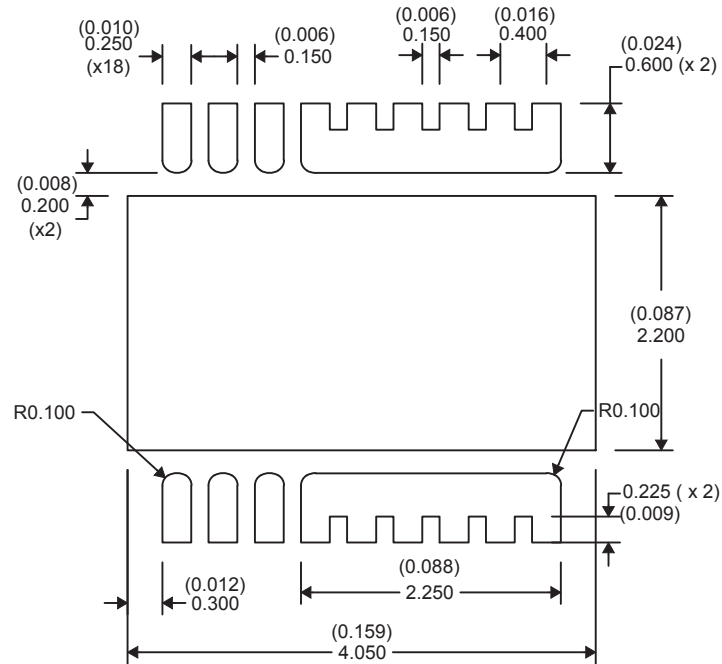

11.3 建议模板开口

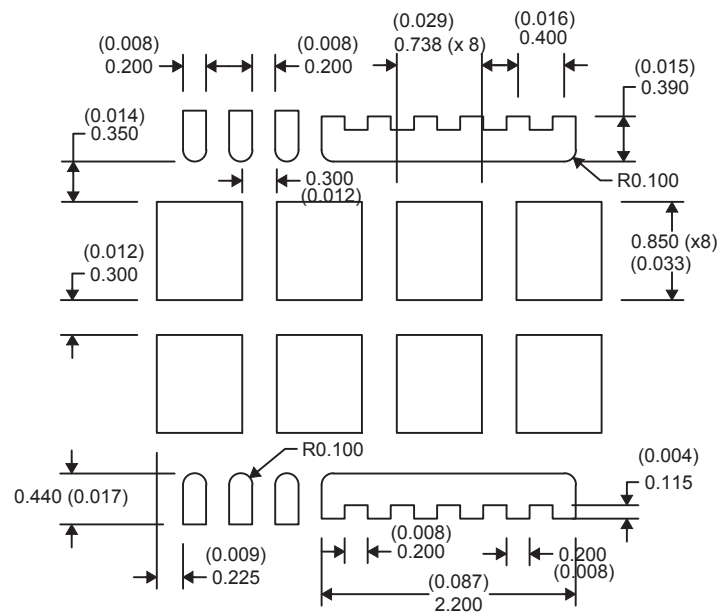

NOTE: 尺寸单位为 mm (英寸)。
模板厚度为 100 μ m。

重要声明

德州仪器(TI)及其下属子公司有权根据 JESD46 最新标准,对所提供的产品和服务进行更正、修改、增强、改进或其它更改,并有权根据 JESD48 最新标准中止提供任何产品和服务。客户在下订单前应获取最新的相关信息,并验证这些信息是否完整且是最新的。所有产品的销售都遵循在订单确认时所提供的TI 销售条款与条件。

TI 保证其所销售的组件的性能符合产品销售时 TI 半导体产品销售条件与条款的适用规范。仅在 TI 保证的范围内,且 TI 认为有必要时才会使用测试或其它质量控制技术。除非适用法律做出了硬性规定,否则没有必要对每种组件的所有参数进行测试。

TI 对应用帮助或客户产品设计不承担任何义务。客户应对其使用 TI 组件的产品和应用自行负责。为尽量减小与客户产品和应用相关的风险,客户应提供充分的设计与操作安全措施。

TI 不对任何 TI 专利权、版权、屏蔽作品权或其它与使用了 TI 组件或服务的组合设备、机器或流程相关的 TI 知识产权中授予的直接或隐含权限作出任何保证或解释。TI 所发布的与第三方产品或服务有关的信息,不能构成从 TI 获得使用这些产品或服务的许可、授权、或认可。使用此类信息可能需要获得第三方的专利权或其它知识产权方面的许可,或是 TI 的专利权或其它知识产权方面的许可。

对于 TI 的产品手册或数据表中 TI 信息的重要部分,仅在没有对内容进行任何篡改且带有相关授权、条件、限制和声明的情况下才允许进行复制。TI 对此类篡改过的文件不承担任何责任或义务。复制第三方的信息可能需要服从额外的限制条件。

在转售 TI 组件或服务时,如果对该组件或服务参数的陈述与 TI 标明的参数相比存在差异或虚假成分,则会失去相关 TI 组件或服务的所有明示或暗示授权,且这是不正当的、欺诈性商业行为。TI 对任何此类虚假陈述均不承担任何责任或义务。

客户认可并同意,尽管任何应用相关信息或支持仍可能由 TI 提供,但他们将独立负责满足与其产品及其在应用中使用的 TI 产品相关的所有法律、法规和安全相关要求。客户声明并同意,他们具备制定与实施安全措施所需的全部专业技术和知识,可预见故障的危险后果、监测故障及其后果、降低有可能造成人身伤害的故障的发生机率并采取适当的补救措施。客户将全额赔偿因在此类安全关键应用中使用任何 TI 组件而对 TI 及其代理造成的任何损失。

在某些场合中,为了推进安全相关应用有可能对 TI 组件进行特别的促销。TI 的目标是利用此类组件帮助客户设计和创立其特有的可满足适用的功能安全性标准和要求的终端产品解决方案。尽管如此,此类组件仍然服从这些条款。

TI 组件未获得用于 FDA Class III (或类似的生命攸关医疗设备)的授权许可,除非各方授权官员已经达成了专门管控此类使用的特别协议。

只有那些 TI 特别注明属于军用等级或“增强型塑料”的 TI 组件才是设计或专门用于军事/航空应用或环境的。购买者认可并同意,对并非指定面向军事或航空航天用途的 TI 组件进行军事或航空航天方面的应用,其风险由客户单独承担,并且由客户独立负责满足与此类使用相关的所有法律和法规要求。

TI 已明确指定符合 ISO/TS16949 要求的产品,这些产品主要用于汽车。在任何情况下,因使用非指定产品而无法达到 ISO/TS16949 要求, TI 不承担任何责任。

	产品		应用
数字音频	www.ti.com.cn/audio	通信与电信	www.ti.com.cn/telecom
放大器和线性器件	www.ti.com.cn/amplifiers	计算机及周边	www.ti.com.cn/computer
数据转换器	www.ti.com.cn/dataconverters	消费电子	www.ti.com.cn/consumer-apps
DLP® 产品	www.dlp.com	能源	www.ti.com.cn/energy
DSP - 数字信号处理器	www.ti.com.cn/dsp	工业应用	www.ti.com.cn/industrial
时钟和计时器	www.ti.com.cn/clockandtimers	医疗电子	www.ti.com.cn/medical
接口	www.ti.com.cn/interface	安防应用	www.ti.com.cn/security
逻辑	www.ti.com.cn/logic	汽车电子	www.ti.com.cn/automotive
电源管理	www.ti.com.cn/power	视频和影像	www.ti.com.cn/video
微控制器 (MCU)	www.ti.com.cn/microcontrollers		
RFID 系统	www.ti.com.cn/rfidsys		
OMAP应用处理器	www.ti.com/omap		
无线连通性	www.ti.com.cn/wirelessconnectivity	德州仪器在线技术支持社区	www.deyisupport.com

邮寄地址: 上海市浦东新区世纪大道1568号, 中建大厦32楼邮政编码: 200122
Copyright © 2016, 德州仪器半导体技术(上海)有限公司

PACKAGING INFORMATION

Orderable Device	Status (1)	Package Type	Package Drawing	Pins	Package Qty	Eco Plan (2)	Lead/Ball Finish (6)	MSL Peak Temp (3)	Op Temp (°C)	Device Marking (4/5)	Samples
BQ500101DPCR	ACTIVE	VSON-CLIP	DPC	8	2500	Pb-Free (RoHS Exempt)	CU NIPDAU	Level-2-260C-1 YEAR	-40 to 125	500101	Samples
BQ500101DPCT	ACTIVE	VSON-CLIP	DPC	8	250	Pb-Free (RoHS Exempt)	CU NIPDAU	Level-2-260C-1 YEAR	-40 to 125	500101	Samples

(1) The marketing status values are defined as follows:

ACTIVE: Product device recommended for new designs.

LIFEBUY: TI has announced that the device will be discontinued, and a lifetime-buy period is in effect.

NRND: Not recommended for new designs. Device is in production to support existing customers, but TI does not recommend using this part in a new design.

PREVIEW: Device has been announced but is not in production. Samples may or may not be available.

OBSOLETE: TI has discontinued the production of the device.

(2) Eco Plan - The planned eco-friendly classification: Pb-Free (RoHS), Pb-Free (RoHS Exempt), or Green (RoHS & no Sb/Br) - please check <http://www.ti.com/productcontent> for the latest availability information and additional product content details.

TBD: The Pb-Free/Green conversion plan has not been defined.

Pb-Free (RoHS): TI's terms "Lead-Free" or "Pb-Free" mean semiconductor products that are compatible with the current RoHS requirements for all 6 substances, including the requirement that lead not exceed 0.1% by weight in homogeneous materials. Where designed to be soldered at high temperatures, TI Pb-Free products are suitable for use in specified lead-free processes.

Pb-Free (RoHS Exempt): This component has a RoHS exemption for either 1) lead-based flip-chip solder bumps used between the die and package, or 2) lead-based die adhesive used between the die and leadframe. The component is otherwise considered Pb-Free (RoHS compatible) as defined above.

Green (RoHS & no Sb/Br): TI defines "Green" to mean Pb-Free (RoHS compatible), and free of Bromine (Br) and Antimony (Sb) based flame retardants (Br or Sb do not exceed 0.1% by weight in homogeneous material)

(3) MSL, Peak Temp. - The Moisture Sensitivity Level rating according to the JEDEC industry standard classifications, and peak solder temperature.

(4) There may be additional marking, which relates to the logo, the lot trace code information, or the environmental category on the device.

(5) Multiple Device Markings will be inside parentheses. Only one Device Marking contained in parentheses and separated by a "~" will appear on a device. If a line is indented then it is a continuation of the previous line and the two combined represent the entire Device Marking for that device.

(6) Lead/Ball Finish - Orderable Devices may have multiple material finish options. Finish options are separated by a vertical ruled line. Lead/Ball Finish values may wrap to two lines if the finish value exceeds the maximum column width.

Important Information and Disclaimer: The information provided on this page represents TI's knowledge and belief as of the date that it is provided. TI bases its knowledge and belief on information provided by third parties, and makes no representation or warranty as to the accuracy of such information. Efforts are underway to better integrate information from third parties. TI has taken and continues to take reasonable steps to provide representative and accurate information but may not have conducted destructive testing or chemical analysis on incoming materials and chemicals. TI and TI suppliers consider certain information to be proprietary, and thus CAS numbers and other limited information may not be available for release.

In no event shall TI's liability arising out of such information exceed the total purchase price of the TI part(s) at issue in this document sold by TI to Customer on an annual basis.

重要声明

德州仪器(TI) 及其下属子公司有权根据 JESD46 最新标准, 对所提供的产品和服务进行更正、修改、增强、改进或其它更改, 并有权根据 JESD48 最新标准中止提供任何产品和服务。客户在下订单前应获取最新的相关信息, 并验证这些信息是否完整且是最新的。所有产品的销售都遵循在订单确认时所提供的TI 销售条款与条件。

TI 保证其所销售的组件的性能符合产品销售时 TI 半导体产品销售条件与条款的适用规范。仅在 TI 保证的范围内, 且 TI 认为有必要时才会使用测试或其它质量控制技术。除非适用法律做出了硬性规定, 否则没有必要对每种组件的所有参数进行测试。

TI 对应用帮助或客户产品设计不承担任何义务。客户应对其使用 TI 组件的产品和应用自行负责。为尽量减小与客户产品和应用相关的风险, 客户应提供充分的设计与操作安全措施。

TI 不对任何 TI 专利权、版权、屏蔽作品权或其它与使用了 TI 组件或服务的组合设备、机器或流程相关的 TI 知识产权中授予的直接或间接权限制作出任何保证或解释。TI 所发布的与第三方产品或服务有关的信息, 不能构成从 TI 获得使用这些产品或服务的许可、授权、或认可。使用此类信息可能需要获得第三方的专利权或其它知识产权方面的许可, 或是 TI 的专利权或其它知识产权方面的许可。

对于 TI 的产品手册或数据表中 TI 信息的重要部分, 仅在没有对内容进行任何篡改且带有相关授权、条件、限制和声明的情况下才允许进行复制。TI 对此类篡改过的文件不承担任何责任或义务。复制第三方的信息可能需要服从额外的限制条件。

在转售 TI 组件或服务时, 如果对该组件或服务参数的陈述与 TI 标明的参数相比存在差异或虚假成分, 则会失去相关 TI 组件或服务的所有明示或暗示授权, 且这是不正当的、欺诈性商业行为。TI 对任何此类虚假陈述均不承担任何责任或义务。

客户认可并同意, 尽管任何应用相关信息或支持仍可能由 TI 提供, 但他们将独自负责满足与其产品及其应用中使用 TI 产品相关的所有法律、法规和安全相关要求。客户声明并同意, 他们具备制定与实施安全措施所需的全部专业技术和知识, 可预见故障的危险后果、监测故障及其后果、降低有可能造成人身伤害的故障的发生机率并采取适当的补救措施。客户将全额赔偿因在此类安全关键应用中使用任何 TI 组件而对 TI 及其代理造成的任何损失。

在某些场合中, 为了推进安全相关应用有可能对 TI 组件进行特别的促销。TI 的目标是利用此类组件帮助客户设计和创立其特有的可满足适用的功能安全性标准和要求的终端产品解决方案。尽管如此, 此类组件仍然服从这些条款。

TI 组件未获得用于 FDA Class III (或类似的生命攸关医疗设备) 的授权许可, 除非各方授权官员已经达成了专门管控此类使用的特别协议。

只有那些 TI 特别注明属于军用等级或“增强型塑料”的 TI 组件才是设计或专门用于军事/航空应用或环境的。购买者认可并同意, 对并非指定面向军事或航空航天用途的 TI 组件进行军事或航空航天方面的应用, 其风险由客户单独承担, 并且由客户独自负责满足与此类使用相关的所有法律和法规要求。

TI 已明确指定符合 ISO/TS16949 要求的产品, 这些产品主要用于汽车。在任何情况下, 因使用非指定产品而无法达到 ISO/TS16949 要求, TI 不承担任何责任。

	产品		应用
数字音频	www.ti.com.cn/audio	通信与电信	www.ti.com.cn/telecom
放大器和线性器件	www.ti.com.cn/amplifiers	计算机及周边	www.ti.com.cn/computer
数据转换器	www.ti.com.cn/dataconverters	消费电子	www.ti.com.cn/consumer-apps
DLP® 产品	www.dlp.com	能源	www.ti.com.cn/energy
DSP - 数字信号处理器	www.ti.com.cn/dsp	工业应用	www.ti.com.cn/industrial
时钟和计时器	www.ti.com.cn/clockandtimers	医疗电子	www.ti.com.cn/medical
接口	www.ti.com.cn/interface	安防应用	www.ti.com.cn/security
逻辑	www.ti.com.cn/logic	汽车电子	www.ti.com.cn/automotive
电源管理	www.ti.com.cn/power	视频和影像	www.ti.com.cn/video
微控制器 (MCU)	www.ti.com.cn/microcontrollers		
RFID 系统	www.ti.com.cn/rfidsys		
OMAP应用处理器	www.ti.com.cn/omap		
无线连通性	www.ti.com.cn/wirelessconnectivity	德州仪器在线技术支持社区	www.deyisupport.com

Mailing Address: Texas Instruments, Post Office Box 655303, Dallas, Texas 75265
Copyright © 2016, Texas Instruments Incorporated